



Parts Identification & Service Manual Proportioning Unit

GA-200

HYDRAULIC AIRLESS

Issue 1.0 - 08/03/19

Ref. NR-00126-ENG



Before installing the unit and starting it up, carefully read all the technical and safety documentation included in this manual. Pay special attention to the information to know and understand the handling and the conditions of use of the unit. All of the information is aimed at enhancing User Safety and avoiding possible breakdowns derived from the incorrect use of the unit.



WARRANTY

HI-TECH SPRAY EQUIPMENT, S. A. (hereinafter "HI-TECH") provides this **LIMITED WARRANTY** (hereinafter "Warranty") to the original purchaser (hereinafter "Customer") covering this equipment and the original HI-TECH manufactured accessories delivered with the equipment (hereinafter "Product") against defects in material or workmanship of the Product (hereinafter "Defect" or "Defective") for a period of two (2) years from the date of first purchase as shown on the original HI-TECH invoice (hereinafter "Warranty Period").

If during the Warranty Period under normal use, the Product is suspected by Customer to be Defective in material or workmanship, it is Customer's responsibility to contact HI-TECH and return the Product to HI-TECH as directed by HI-TECH, freight prepaid. If HI-TECH determines that the Product is Defective and that such Defect is covered by this Warranty, HI-TECH will credit Customer for the reasonable freight charges incurred by Customer in returning the Defective Product to HI-TECH, and HI-TECH (or its authorized agent) will, at HI-TECH's option, repair or replace the Product, subject to the following:

Original Invoice: The original invoice must be kept as proof of the date of first sale and the Product serial number. The Warranty does not cover any Product if the Original Invoice appears to have been modified or altered, or when the serial number on the Product appears to have been altered or defaced.

Product Maintenance: It is the Customer's responsibility to maintain the Product properly. See your maintenance schedule and owner's manual for details. The Warranty does not cover an improperly maintained Product.

Non-HI-TECH Components and Accessories: Non-HI-TECH manufactured components and accessories that are used in the operation of the Product are not covered by this Warranty. Such components and accessories shall be subject to the warranty offered to the Customer, if any, by the original manufacturer of such component or accessory.

Other Warranty Exclusions: The Warranty does not cover any Product that HI-TECH determines has been damaged or fails to operate properly due to misuse, negligence, abuse, carelessness, neglect, or accident. By way of example only, this includes:

- Normal wear and tear.
- Improper or unauthorized installation, repair, alteration, adjustment or modification of the Product.
- Use of heating devices, pumping equipment, dispensers, or other parts or accessories with the Product that have not been approved or manufactured by HI-TECH.
- Failure to follow the operating instructions and recommendations provided by HI-TECH.
- Cosmetic damage.
- Fire, flood, "acts of God," or other contingencies beyond the control of HI-TECH.

THE WARRANTY DESCRIBED HEREIN IS THE EXCLUSIVE REMEDY FOR THE CUSTOMER AND IS IN LIEU OF ALL OTHER WARRANTIES, EXPRESS, IMPLIED, STATUTORY OR OTHERWISE, AND THE IMPLIED WARRANTIES OF MERCHANTABILITY AND FITNESS FOR A PARTICULAR PURPOSE AND ALL OTHER WARRANTIES ARE HEREBY DISCLAIMED. TO THE FULLEST EXTENT PERMITTED BY LAW, HI-TECH SHALL NOT BE RESPONSIBLE, WHETHER BASED IN CONTRACT, TORT (INCLUDING, WITHOUT LIMITATION, NEGLIGENCE), WARRANTY OR ANY OTHER LEGAL OR EQUITABLE GROUNDS, FOR ANY CONSEQUENTIAL, INDIRECT, INCIDENTAL, LOST PROFITS, SPECIAL, PUNITIVE OR EXEMPLARY DAMAGES, WHETHER TO PERSON OR PROPERTY, ARISING FROM OR RELATING TO THE PRODUCT, EVEN IF HI-TECH HAS BEEN ADVISED OF THE POSSIBILITY OF SUCH LOSSES OR DAMAGES.

Non-Warranty Service by HI-TECH: If HI-TECH determines that the suspected Defect of the Product is not covered by this Warranty, disposition of the Product will be made pursuant to the terms and conditions of HI-TECH's written estimate on a time and materials basis.

Continuing Warranty for Products Repaired or Replaced under Warranty: Following the repair or replacement of a Product covered by this Warranty, such Product will continue to be subject to the original Warranty for the remainder of original Warranty Period or for three (3) months from the repair or replacement date, whichever is longer.

No Rights Implied: Nothing in the sale, lease or rental of any Product by HI-TECH shall be construed to grant any right, interest or license in or under any patent, trademark, copyright, trade secret or other proprietary right or material owned by anyone; nor does HI-TECH encourage the infringement of same.

Exclusive Warranty: This writing is the final, complete, and exclusive expression of the Warranty covering the Product. Any statements made by HI-TECH, its employees or agents that differ from the terms of this Warranty shall have no effect. It is expressly understood that Customer's acceptance of this Warranty, by performance or otherwise, is upon and subject solely to the terms and conditions hereof, and any additional or different terms and conditions proposed or expressed by Customer or anyone, whether in writing or otherwise, are null and void unless specifically agreed to in writing by an Officer of HI-TECH.

GA-200

HYDRAULIC AIRLESS



Parts Identification & Manual Service

All information provided in this Service Manual is assumed to be correct; although this does not constitute any implicit or explicit liability or guarantee. HI-TECH reserves the right at any time and without prior warning to make all improvements and modifications necessary to this Service Manual, in order to rectify any possible typographical errors, supplement the information contained or insert changes predicated by the performance or use of the unit.

SAFETY AND HANDLING

The **GA-200 Hydraulic Airless** series metering unit has been designed and manufactured in full compliance to the provisions of Machine Directive 89/392/CEE in its modified form and the National Regulations that transpose it. It also meets all European Directives concerning electromagnetic compatibility and electrical safety and the provisions of the Harmonised Norms that are applicable.

This chapter contains information on the safety, handling and use of the **GA-200 Hydraulic Airless** series metering unit.



Before installing the unit and starting it up, carefully read all the technical and safety documentation included in this manual. Pay special attention to the information to know and understand the operation and the conditions of use of the unit. All of the information is aimed at enhancing User Safety and avoiding possible breakdowns derived from the incorrect use of the unit.

WARNING! Establishes information to alert on a situation that might cause serious injuries if the instructions are not followed.

PRECAUTION! Establishes information that indicates how to avoid damage to the unit or how to avoid a situation that could cause minor injuries.

NB: is relevant information on a procedure being carried out.

Careful study of this manual will enable the operator to know the characteristics of the unit and the operating procedures. By following the instructions and recommendations contained herein, you will reduce the potential risk of accidents in the installation, use or maintenance of the unit; you will provide a better opportunity for incident-free operation for a longer time, greater output and the possibility of detecting and resolving problems fast and simply.

Keep this Service Manual for future consultation of useful information at all times. If you lose this manual, ask for a new copy from your **HI-TECH** local distributor or directly contact **HI-TECH SPRAY EQUIPMENT**.

WARNING! The design of the **GA-200 Hydraulic Airless** series metering unit does not allow its use in potentially explosive atmospheres or to exceed the pressure and temperature limits described in the technical specifications of this manual.



GA-200 HYDRAULIC AIRLESS

Parts Identification & Manual Service

When working with the unit, it is recommended that the operator wear suitable clothing and elements of personal protection, including, without limitation, gloves, protective goggles, safety footwear and face masks. Use breathing equipment when working with the machine in enclosed spaces or in areas with insufficient ventilation. The introduction and follow-up of safety measures must not be limited to those described in this manual. Before starting up the machine, a comprehensive analysis must be made of the risks derived from the products to be dispensed, the type of application and the working environment



To prevent all possible bodily harm caused by incorrect handling of the raw materials and solvents used in the process, carefully read the safety information provided by your supplier.

Deal with the waste caused according to current regulations.



Disconnect the unit from the power supply before carrying out any operation inside the electrical console.

The electrical maintenance of the machine must only be performed by a qualified electrician.



To avoid damage caused by the impact of pressurized fluids, do not open any connection or perform maintenance work on components subject to pressure until the pressure has been completely eliminated.



Use suitable protection when operating, maintaining or remaining in the operating area of the unit. This includes, but is not limited to, the use of masks, protective goggles, gloves, shoes and safety clothing.

The unit includes components that reach temperatures that are liable to cause burns. The hot parts of the unit must not be handled until they have cooled.



To prevent serious harm by crushing or loss of limbs, do not work with the unit without the safety guards installed on all moving parts. Make sure that all of the safety protections are correctly reinstalled after all repair or maintenance work is completed.

GA-200

HYDRAULIC AIRLESS



Parts Identification & Manual Service

ATTENTION:

This equipment generates very high fluid pressure. High pressure spray can cause serious injury. Read and understand all instructions before operating.

Never point the spray gun at anyone or at any part of the body. Never put hand, fingers over the spray tip.

Always have the tip guard in place on the spray gun while spraying.

High pressure fluid in the hoses can be very dangerous. If the hose develops a leak, split or rupture due to any kind of wear, damage or misuse, the high-pressure spray emitted from it can cause a fluid injection injury or other serious bodily injury or property damage.

Never use a damaged hose

Tighten all fluid connections securely before each use. High pressure fluid can dislodge a loose coupling or allow high pressure spray to be emitted from the coupling.

Proper hose grounding continuity is essential to maintaining a grounded spray system.

If any fluid appears to penetrate your skin, get emergency medical care at once. Do not treat as a simple cut. Tell the doctor exactly what fluid was injected.

All chemicals used in the pump must be compatible with the wetted parts of the pump.

PRESSURE HAZARD

This pump can develop 240 bar working pressure. Be sure that all spray equipment and accessories used are rated to withstand this pressure. Do not exceed the maximum working pressure of any component or accessory used in the system.

FIRE OR EXPLOSION HAZARD

Static electricity is created by the flow of fluid through the pump and hose. If every part of the spray equipment is not properly grounded, sparking may occur and the system may become hazardous. Sparking may also occur when plugging in or unplugging a power supply cord. Sparks can ignite fumes from solvents and the fluid being sprayed, dust particles, whether you are spraying indoors or outdoors, and can cause a fire or explosion.

If you experience any static sparking or even a slight shock while using the equipment, stop spraying immediately. Check the system for proper grounding. Do not use the system again until the problem has been identified and corrected.

GAS ENGINE (WHERE APPLICABLE)

Always place pump outside of structure in fresh air. Keep all solvents away from the engine exhaust. Never fill fuel tank with a running or hot engine. Hot surface can ignite spilled fuel. Always attach ground wire from pump unit to a grounded object, such as a metal water pipe. Refer to engine owner's manual for complete safety information.

PRESSURE RELIEVE PROCEDURE

To reduce the risk of serious bodily injury, including fluid injection, splashing fluid or solvent in the eyes or on the skin, or injury from moving parts or electric shock, always follow this procedure whenever you shut off the sprayer, when checking or servicing any part of the spray system, when installing, cleaning or changing spray tips, and whenever you stop spraying:



GA-200 HYDRAULIC AIRLESS

Parts Identification & Manual Service

- Engage the gun safety latch.
- Turn the ON/OFF switch to OFF (red).
- Unplug the power supply cord.
- Disengage the gun safety latch. Hold a metal part of the gun to the side of a grounded metal pail, and trigger the gun to relieve pressure.
- Engage the gun safety latch
- Open the pressure drain valve, having a container ready to catch the drainage.

GROUNDING INSTRUCTIONS

Electric models must be grounded. In the event of an electrical short circuit, grounding reduces the risk of electric shock by providing an escape wire for the electric current. This product is equipped with a cord having a grounding wire with an appropriate grounding plug. The plug must be plugged into an outlet that is properly installed and grounded in accordance with all local codes and ordinances.

DANGER! - Improper installation of the grounding plug can result in a risk of electric shock. If repair or replacement of the cord or plug is necessary, do not connect the green grounding wire to either flat blade terminal. The wire with insulation having a green outer surface with or without yellow stripes is the grounding wire and must be connected to the grounding pin.

NB: Before starting to work the pump must be connected to ground. The pump must be connected to ground with a ground wire which is supplied with the pump (4mm² of section and a clamp).

GASOLINE ENGINE SAFETY

- Honda engines are designed to give safe and dependable service if operated according to instructions. Read and understand the Honda Owner's Manual before operating the engine. Failure to do so could result in personal injury or equipment damage.
- To prevent fire hazards and to provide adequate ventilation, keep the engine at least 1 meter (3 feet) away from buildings and other equipment during operation. Do not place flammable objects close to the engine.
- Children and pets must be kept away from the area of operation due to a possibility of burns from hot engine components or injury from any equipment the engine may be used to operate.
- Know how to stop the engine quickly, and understand the operation of all controls. Never permit anyone to operate the engine without proper instructions.
- Gasoline is extremely flammable and is explosive under certain conditions.
- Refuel in a well-ventilated area with the engine stopped.
- Do not smoke or allow flames or sparks in the refuelling area or where gasoline is stored.
- Do not overfill the fuel tank. After refuelling, make sure the tank cap is closed properly and securely.
- Be careful not to spill fuel when refuelling. Fuel vapor or spilled fuel may ignite. If any fuel is spilled, make sure the area is dry before starting the engine.

GA-200

HYDRAULIC AIRLESS

Parts Identification & Manual Service



- Never run the engine in an enclosed or confined area. Exhaust contains poisonous carbon monoxide gas; exposure may cause loss of consciousness and may lead to death.
- The muffler becomes very hot during operation and remains hot for a while after stopping the engine. Be careful not to touch the muffler while it is hot. To avoid severe burns or fire hazards, let the engine cool before transporting it or storing it indoors.
- Never ship/transport unit with gasoline in the tank.



OPERATION

- Attach and airless spray gun to the spray hose. Do not attach the tip to the spray gun yet. Remove the tip if it is already attached.
- Check the hydraulic fluid level daily before starting the unit. The hydraulic fluid level should be at the "Full" mark, on the dipstick.
- For gas models, check the engine oil level daily before starting the unit. The gasoline engine oil level is determined by the engine manufacturer.
- Place the suction pipe into a container of solvent/water.
- Place the bleed hose into a metal waste container.
- Set the pressure to minimum by turning the pressure control knob fully counter clockwise.
- Open the hydraulic shut-off valve located on the hydraulic pressure hose. The handle should be in line with the hose.
- Open the bleed valve by turning it fully counter clockwise.
- Start the engine or turn on the electric motor.
 - a) To start the gas engine:
 - Move the fuel valve lever to the open position.
 - Move the throttle lever to its middle point.
 - Move the choke lever to the closed position for a cold engine or to the open position for a warm engine.
 - Turn the engine switch to the ON position.
 - Pull the starter rope briskly until the engine starts.
 - b) To start the electric motor, move the ON/OFF switch to the ON position.
- Turn the pressure control knob clockwise approximately 1/3 of the way down to increase pressure until the sprayer cycles evenly and solvent flows freely from the bleed hose.
- Allow the sprayer to run for 15-30 seconds to flush the test fluid out through the bleed hose and into the waste container.
- Turn off the unit
 - a) To turn off the gas engine:
 - Set the pressure to minimum by turning the pressure control knob fully counter clockwise.
 - Move the throttle lever to the slow position.
 - Turn the engine switch to the OFF position
 - b) To turn off the electric motor:
 - Set the pressure to minimum by turning the pressure control knob fully counter clockwise.
 - Move the ON/OFF switch to the OFF position.

GA-200

HYDRAULIC AIRLESS

Parts Identification & Manual Service



PREPARING TO PAINT

Before painting, it is important to make sure that the fluid in the system is compatible with the paint that is going to be used.

NB: *Incompatible fluids and paint may cause the valves to become stuck closed, which would require disassembly and cleaning of the sprayer's fluid suction.*



CAUTION! *Always keep the trigger lock on the spray gun in the locked position while preparing the system.*

- Place the suction pipe into a container of the appropriate solvent.

NB: *If you are spraying a water-based latex, flush with warm, clean water. If you are using any other material, check with the material manufacturer for a compatible solvent.*

- Place the bleed hose into a metal waste container.
- Set the pressure to minimum by turning the pressure control knob fully counter clockwise.
- Open the hydraulic shut-off valve located on the hydraulic pressure hose. The handle should be in line with the hose.
- Open the bleed valve by turning it fully counter clockwise.
- Start the engine or turn on the electric motor.
 - a) To start the gas engine:
 - Move the fuel valve lever to the open position.
 - Move the throttle lever to its middle point.
 - Move the choke lever to the closed position for a cold engine or to the open position for a warm engine.
 - Turn the engine switch to the ON position.
 - Pull the starter rope briskly until the engine starts.
 - b) To start the electric motor, move the ON/OFF switch to the ON position.
- Turn the pressure control knob clockwise approximately 1/3 of the way down to increase pressure until the sprayer cycles evenly and solvent flows freely from the bleed hose.
- Allow the sprayer to run for 15-30 seconds to flush the test fluid out through the bleed hose and into the waste container.
- Turn off the unit.
 - a) To turn off the gas engine:
 - Set the pressure to minimum by turning the pressure control knob fully counter clockwise.
 - Move the throttle lever to the slow position.
 - Turn the engine switch to the OFF position.



b) To turn off the electric motor:

Set the pressure to minimum by turning the pressure control knob fully counter clockwise.

Move the ON/OFF switch to the OFF position.

NB: Make sure that the spray gun does not have a tip or tip guard installed.

- Close the bleed valve by turning it fully clockwise.
- Start the engine or turn on the electric motor.
- Turn the pressure control knob clockwise approximately 1/3 of the way down to increase pressure.
- Unlock the gun by turning the gun trigger lock to the unlocked position.
- Trigger the gun into the metal waste container until the old solvent is gone and fresh solvent is coming out of the gun.
- Lock the gun by turning the gun trigger lock to the locked position.
- Set down the gun and increase the pressure by turning the pressure control knob slowly clockwise.
- Check the entire system for leaks. If leaks occur, follow the “Pressure Relief Procedure” in this manual before tightening any fitting or hoses.
- Follow the “Pressure Relief Procedure” in this manual before changing from solvent to paint.



WARNING! Be sure to follow the pressure relief procedure when shutting the unit down for any purpose, including servicing or adjusting any part of the spray system, changing or cleaning spray tips, or preparing for cleanup.

PAINTING

- Place the suction pipe into a container of paint.
 - Place the bleed hose into a metal waste container.
 - Set the pressure to minimum by turning the pressure control knob fully counter clockwise.
 - Open the hydraulic shut-off valve located on the hydraulic pressure hose. The handle should be in line with the hose.
 - Open the bleed valve by turning it fully counter clockwise.
 - Start the engine or turn on the electric motor.
- a) To start the gas engine:
- Move the fuel valve lever to the open position.
- Move the throttle lever to its middle point.

GA-200

HYDRAULIC AIRLESS



Parts Identification & Manual Service

Move the choke lever to the closed position for a cold engine or to the open position for a warm engine.

Turn the engine switch to the ON position.

Pull the starter rope briskly until the engine starts.

- b) To start the electric motor, move the ON/OFF switch to the ON position.
- Turn the pressure control knob clockwise approximately 1/3 of the way down to increase pressure until the sprayer cycles evenly and paint flows freely from the bleed hose.
- Turn off the unit:
 - a) To turn off the gas engine.

Set the pressure to minimum by turning the pressure control knob fully counter clockwise.

Move the throttle lever to the slow position.

Turn the engine switch to the OFF position.
 - b) To turn off the electric motor.

Set the pressure to minimum by turning the pressure control knob fully counter clockwise.

Move the ON/OFF switch to the OFF position.
- Remove the bleed hose from the waste container and place it into the container of paint.
- Close the bleed valve by turning it fully clockwise.
- Start the engine or turn on the electric motor.
- Turn the pressure control knob clockwise approximately 1/3 of the way down to increase pressure.
- Unlock the gun by turning the gun trigger lock to the unlocked position.



WARNING! Ground the gun by holding it against the edge of the metal container while flushing. Failure to do so may lead to a static electric discharge, which may cause a fire.

- Trigger the gun into the metal waste container until all air and solvent is flushed from the spray hose and paint is flowing freely from the gun.
- Lock the gun by turning the gun trigger lock to the locked position.
- Turn off the unit.
- Attach tip guard and tip to the gun as instructed by the tip guard or tip manuals.



WARNING! POSSIBLE INJECTION HAZARD. Do not spray without the tip guard in place. Never trigger the gun unless the tip is in either the spray or the unclog position. Always engage the gun trigger lock before removing, replacing or cleaning tip.



Start the engine or turn on the electric motor.

Increase the pressure by turning the pressure control knob slowly clockwise and test the spray pattern on a piece of cardboard. Adjust the pressure control knob until the spray from the gun is completely atomized.

NB: *Turning the pressure up higher than needed to atomize the paint will cause premature tip wear and additional over spray.*

PRESSURE RELIEVE PROCEDURE



WARNING! *Be sure to follow the pressure relief procedure when shutting the unit down for any purpose, including servicing or adjusting any part of the spray system, changing or cleaning spray tips, or preparing for cleanup.*

- Lock the gun by turning the gun trigger lock to the locked position.
- Turn off the unit
 - a) To turn off the gas engine
 - Set the pressure to minimum by turning the pressure control knob fully counter clockwise.
 - Move the throttle lever to the slow position
 - Turn the engine switch to the OFF position.
 - b) To turn off the electric motor.
 - Set the pressure to minimum by turning the pressure control knob fully counter clockwise.
 - Move the ON/OFF switch to the OFF position.
- Close the hydraulic shut -off valve on the hydraulic pressure hose.
- Unlock the gun by turning the gun trigger lock to the unlocked position.
- Hold the metal part of the gun firmly to the side of a metal waste container to ground the gun and avoid a build-up of static electricity.
- Trigger the gun to remove any pressure that may still be in the hose.
- Lock the gun by turning the gun trigger lock to the locked position.
- Place the bleed hose into the metal waste container.
- Open the bleed valve by turning it fully counter clockwise.

GA-200

HYDRAULIC AIRLESS

Parts Identification & Manual Service



CLEANUP



WARNING!

Special clean-up instructions for use with flammable solvent.

- Always flush spray gun preferably outside and at least one hose length from spray pump.
- If collecting flushed solvents in a one-gallon metal container, place it into an empty five-gallon container, then flush solvents.
- Area must be free of flammable vapours.
- Follow all clean-up instructions.



CAUTION! *The sprayer, hose, and gun should be cleaned thoroughly after daily use. Failure to do so permits material to build up, seriously affecting the performance of the unit.*

WARNING! *Always spray at minimum pressure with the gun nozzle tip removed when using mineral spirits or any other solvent to clean the sprayer, hose, or gun. Static electricity build-up may result in a fire or explosion in the presence of flammable vapours.*

- Follow the "Pressure Relief Procedure" found in the Operation section of this manual.
- Remove the gun tip and tip guard and clean with a brush using the appropriate solvent.
- Place the suction pipe into a container of the appropriate solvent.



CAUTION! *Use only compatible solvents when cleaning out oil-based enamels, lacquers, coal tar, and epoxies. Check with the fluid manufacturer for the recommended solvent.*

- Place the bleed hose into the metal waste container.
- Set the pressure to minimum by turning the pressure control knob fully counter clockwise.
- Open the hydraulic shut-off valve located on the hydraulic pressure hose. The handle should be in line with the hose.
- Open the bleed valve by turning it fully counter clockwise.
- Start the engine or turn on the electric motor.
- Allow the solvent to circulate through the unit and flush the paint out of the bleed hose into the metal waste container.
- Turn off the unit.
- Close the bleed valve by turning it fully clockwise.
- Start the engine or turn on the electric motor



GA-200 HYDRAULIC AIRLESS

Parts Identification & Manual Service



WARNING! Ground the gun by holding it against the edge of the metal container while flushing. Failure to do so may lead to a static electric discharge, which may cause a fire.

- Trigger the gun into the metal waste container until the paint is flushed out off the hose and solvent is coming out of the gun.
- Continue to trigger the spray gun into the waste container until the solvent coming out of the gun is clean.

NB: For long term or cold weather storage, pump mineral sprits through the entire system.

- Follow the “Pressure Relief Procedure” found in the Operation section of this manual.
- Store the unit in a clean, dry area.



WARNING!
Do not store the unit under pressure.

CLEANING A CLOGGED TIP

1. Follow the “Pressure Relief Procedure” in the Operation section on this manual.
2. In the tip clogs, rotate the tip handle 180° until the arrow on the handle is facing the opposite of the spray direction and the handle clicks in the reverse position.
3. Trigger the gun once so that the pressure can blow the clog out. NEVER use the tip in the reverse position for more than ONE trigger pull at a time. This procedure can be repeated until the tip is free of clogging.



WARNING! The flow from the spray tip is at very high pressure. Contact with any body part may be dangerous. Do not place finger on gun outlet. Do not point the gun at any person. Never operate the spray gun without the proper tip guard.

GA-200

HYDRAULIC AIRLESS

Parts Identification & Manual Service



MAINTENANCE



WARNING! Before proceeding, follow the Pressure Relief Procedure outlined previously in this manual. Additionally, follow all other warnings to reduce the risk of an injection injury, injury from moving parts or electric shock. Always unplug the sprayer before servicing.

DAILY MAINTENANCE

Two daily procedures are required for routine operator maintenance on this unit:

- Lubricating the upper packing.
- Cleaning the rock catcher.

Lubricating the Upper Packings

- Clean out the paint that has seeped past the upper packings into the packing oil reservoir above the fluid section.
- Fill the packing oil reservoir 1/2 full with Piston Lube supplied by the factory. This will extend packing life.

NB: Do not over -fill the reservoir so that it overflows and drips into the paint.

MAINTAINING THE HYDRAULIC SYSTEM



CAUTION! Use of Hydraulic Fluid DIN 51524 standard, section 1 & 2 (for example ISO VG 46) is mandatory in the hydraulic system. Do not use any other hydraulic fluid. Use of any other hydraulic fluid may seriously damage the hydraulic system and will void the warranty.

1. Check the hydraulic fluid daily. It should be at the "Full" mark on the dipstick. If it is low, add only Hydraulic Fluid DIN 51524 standard, section 1 & 2 (for example ISO VG 46). Never add or change hydraulic fluid except in a clean, dust-free area. Contamination of the hydraulic fluid will shorten hydraulic pump life and may void warranty.
2. Change the hydraulic fluid every twelve months. Drain the old fluid from the tank. Start the unit at just enough pressure to operate the fluid section. Run the unit at this low pressure for at least 5 minutes. This removes air from the system. Check the fluid level after this procedure.
3. The hydraulic system has an external, replaceable hydraulic filter. Change the filter every twelve months.



GA-200 HYDRAULIC AIRLESS

Parts Identification & Manual Service

BASIC ENGINE MAINTENANCE (GAS ENGINE)

For detailed engine maintenance and technical specifications refer to the separate gasoline engine manual.

All service to the engine should be performed by an authorized Honda Power Equipment dealer.

DAILY

- Check engine oil level, and fill as necessary.
- Check gasoline level, and fill as necessary.



WARNING! Always follow the fueling procedure outlined earlier in this manual.

FIRST 20 HOURS

1. Change engine oil.

EVERY 100 HOURS

1. Change engine oil.
2. Clean the sediment cup.
3. Clean and re-gad the spark plug.
4. Clean the spark arrestor

WEEKLY

Remove the air filter cover and clean the element. In very dusty environments, check the filter daily. Replace the element as needed. Replacement elements can be purchased from your local Honda dealer.

ENGINE OPERATION SERVICE

1. Clean and oil air filter pad on gasoline engine every 25 hours or once weekly. Do not permit the air intake screen around the fly wheel of the gas engine to load up with paint or trash. Clean it regularly. The service life and efficiency of the gas engine model depends upon keeping the gasoline engine running properly. Change the oil in the engine every 100 hours. Failure to observe this may result in engine overheating. Consult the engine manufacturer's service manual provided.
2. To conserve fuel, service life, and efficiency of the unit, always operate the gasoline engine at the lowest RPM at which it runs smoothly without labouring and delivers the amount required for the particular painting operation. Higher RPM does not produce higher working pressure. The gasoline engine is connected to the hydraulic pump by a pulley combination designed to produce full paint delivery of 1.2 GPM at maximum RPM.
3. The warranty on gasoline engines or electric motors is limited to the original manufacturer.



TROUBLESHOOTING

TROUBLE	POSSIBLE CAUSE	SOLUTION
Pump delivers on upstroke only or goes up slowly and down fast.	<ul style="list-style-type: none"> ▪ Lower foot valve ball is not seating due to trash or wear. ▪ Material too viscous to siphon. ▪ Air leaking in on siphon side or damaged siphon hose. Siphon may be too small for heavy material. 	<ul style="list-style-type: none"> ▪ Remove foot valve assembly. Clean and inspect. Test foot valve by filling with water; if ball fails to seal the seat, replace ball. ▪ Thin material, contact manufacturer for proper thinning procedures. ▪ Tighten all connections between pump and paint container. If damaged, replace. Switch to larger diameter siphon set.
Pump delivers on down stroke only or goes up fast and down slowly.	<ul style="list-style-type: none"> ▪ Upper ball is not seating due to trash or wear. ▪ Lower packing set is worn. 	<ul style="list-style-type: none"> ▪ Check upper seat and ball with water. If ball fails to seal, replace seat. ▪ Replace packing set if worn.
Pump moves up and down fast, delivering material.	<ul style="list-style-type: none"> ▪ Material container is empty or material is too thick to flow through siphon hose. ▪ Bottom ball stuck to foot valve seat. ▪ Siphon hose is kinked or loose. 	<ul style="list-style-type: none"> ▪ Refill with new material. If too thick, remove siphon hose, immerse fluid section in material, and start pump to prime. Add thinner to material. Change to bigger siphon set. Open bleed valve to remove air and restart pump. ▪ Remove foot valve. Clean ball and seat. ▪ Straighten.
Pump moves up and down slowly when spray gun is shut off.	<ul style="list-style-type: none"> ▪ Loose connections. Bleed valve is open partially or bleed valve is worn. Lower packing seat is worn. ▪ Upper and/or lower ball not seating. 	<ul style="list-style-type: none"> ▪ Check all connections between pump and gun. Tighten as necessary. If material is flowing from bleed hose, close bleed valve or replace, if necessary. Should none of the above be evident, replace lower packing. ▪ Reseat balls by cleaning.
Not enough fluid pressure at gun.	<ul style="list-style-type: none"> ▪ Spray tip is worn. ▪ Outlet filter or gun filter is clogged. ▪ Low voltage and/or inadequate amperage. ▪ Hose size or length is too small or too long. 	<ul style="list-style-type: none"> ▪ Replace. ▪ Clean or replace filter. ▪ Check electrical service. Correct as required. ▪ Increase hose size to minimize pressure drop through hose and/or reduce hose length.
Pump chatters on up or down stroke.	<ul style="list-style-type: none"> ▪ Solvent has caused upper packing to swell. 	<ul style="list-style-type: none"> ▪ Replace packing.



TROUBLE	POSSIBLE CAUSE	SOLUTION
Oil motor stalls at bottom (no unusual heat problems).	<ul style="list-style-type: none"> ▪ Fluid pump piston seat unthreaded. ▪ Valve sticking or oil motor trip rod shifter assembly separated. 	<ul style="list-style-type: none"> ▪ If connecting rod is okay, remove cylinder head plug and pop valve down. Replace plug and start machine. If machine cycles up and stops at bottom again, then problem is piston seat on fluid pump. Check piston seat. Repair or replace as necessary. If piston seat is okay and problem does not change, check oil motor. ▪ Remove valve and check for scratches and rough movement when sliding it up and down. Replace valve and spool in this condition. Check trip rod for possible separation and spool in this condition. Check trip rod for possible separation.
Oil motor stalls at top (no unusual heat problems).	<ul style="list-style-type: none"> ▪ Valve sticking. ▪ Broken spring retainer (valve rod assembly). ▪ Broken spring or valve rod. ▪ Air in hydraulic motor. ▪ Air in fluid pump 	<ul style="list-style-type: none"> ▪ Remove valve and check for scratches and rough movement when sliding it up and down. Replace valve and spool in this condition. ▪ Replace valve rod assembly. ▪ Replace valve rod assembly ▪ Reset valve. Purge Air, generally accomplished by low pressure cycling of motor/pump assembly for 5-10 minutes. Check for causes of air introduction: <ul style="list-style-type: none"> ○ Loose fittings in tank. ○ Loose fittings on hydraulic pump. ○ Loose hose connections. ○ Low oil in reservoir. ▪ Stall at top can occur randomly when fluid pump picks up air. Reset valve. Avoid air in the fluid pump.

GA-200

HYDRAULIC AIRLESS

Parts Identification & Manual Service



TECHNICAL SPECIFICATIONS

Mechanical (with Electrical Motor)

Maximum working pressure: _____ 232,5 kgf/cm² (22,8 MPa) / 3306 psi / 228 bar
Max. Production: _____ 5,7 l/min / 1,51 gal/min
Maximum PCD size: _____ 1 gun → 0,036"
_____ 2 guns → 0,026"
Electric Motor Power: _____ 4,02 HP / 3 kW (220v 50 Hz)
Approximate weight (hydraulic tank empty): _____ 66 kg / 145,5 lb
Approximate weight (hydraulic tank full): _____ 70,4 kg / 155,2 lb
Hydraulic tank capacity: _____ 5 l / 1,32 gal

Mechanical (with Gasoline Engine)

Maximum working pressure: _____ 232,5 kgf/cm² (22,8 MPa) / 3306 psi / 228 bar
Max. Production: _____ 6,4 l/min / 1,69 gal/min
Maximum PCD size: _____ 1 gun → 0,043"
_____ 2 guns → 0,033"
Gasoline Motor Power: _____ 5,5 HP / 4,1 kW
Approximate weight (hydraulic & gasoline tanks empty): _____ 72 kg / 158,7 lb
Approximate weight (hydraulic & gasoline tanks full): _____ 78,5 kg / 173 lb
Hydraulic tank capacity: _____ 5 l / 1,32 gal
Gasoline tank capacity: _____ 3 l / 0,8 gal

Hydraulic oil type: _____ DIN 51524 standard, section 1 & 2 (for example ISO VG 46)
Gasoline Fuel type (*): _____ E5 (95/98 octane without oil)
Motor Lubricant (*): _____ SAE 10/30W

(*) Only GA-200 G model

Dimensions: _____ H: 1352 mm / 53 in
_____ W: 945 mm / 37 in
_____ L: 745 mm / 29 in

GENERAL DESCRIPTION

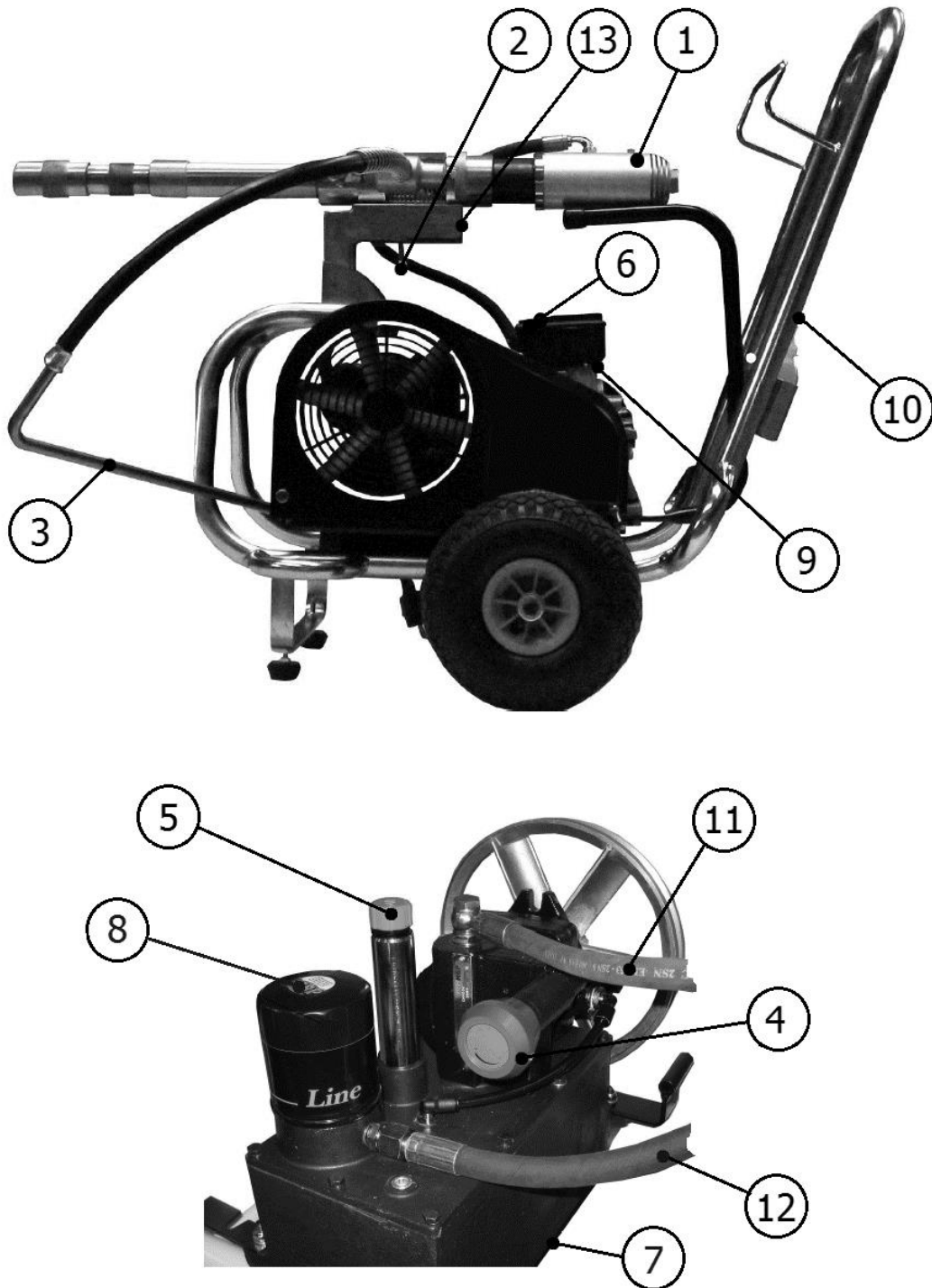

Figure 1. GA-200 model, General Description.



Table 1. GA-200 model, General Description

Item.	Description
1	Pump
2	Hydraulic Shut-Off Valve
3	Drain Valve
4	Pressure Control
5	Hydraulic Fluid Level
6	On/Off Switch
7	Hydraulic Tank
8	Hydraulic Filter
9	Electric Motor 4 HP / 3kW 220v 50Hz (GA-200 E)
	Gasoline Engine Honda 5,5 HP / 4,1 kW (GA-200 G)
10	Trolley
11	Inlet Hydraulic System (Pressure Line)
12	Outlet Hydraulic System (Return Lin)
13	Ground & Wire Ground

Table 2. GA-200, Available models

Description	Part Number
Model with Electric Motor	GA-200E
Model with Gasoline Engine	GA-200G



GA-200
HYDRAULIC AIRLESS

**Parts Identification
& Manual Service**

MOTOR PUMP

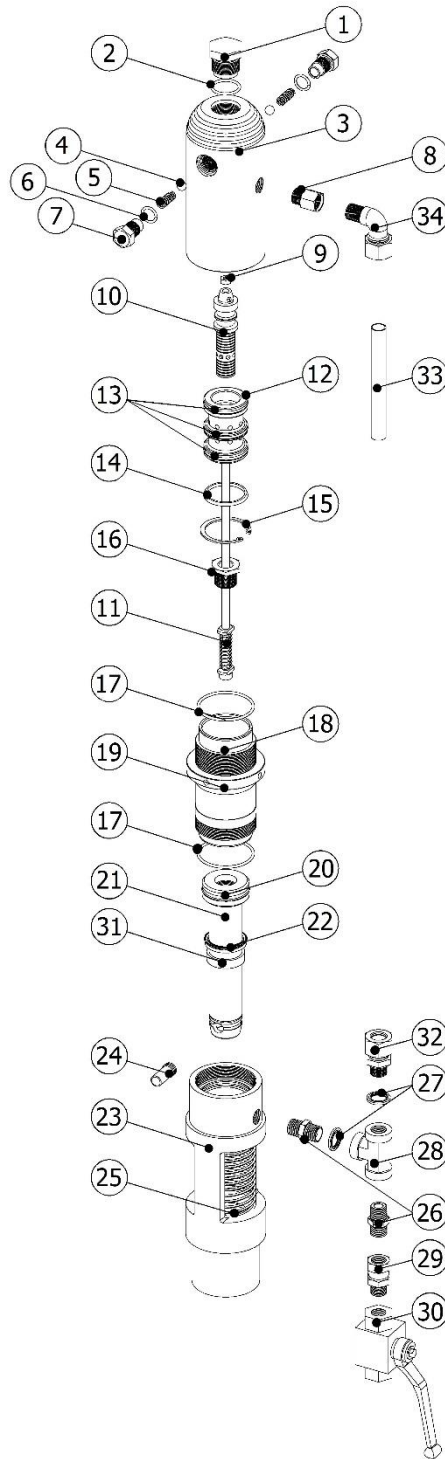

Figure 2. Motor Pump, Parts List.



Table 3. Motor Pump, Parts List

Item	Description	Part Number	Qty.
1	Plug	ASP-07	1
2	O-Ring	ASP-08	1
3	Cylinder Hydraulic Pump	ASP-09	1
4	Ball	ASP-10	2
5	Spring	ASP-11	2
6	O-Ring	ASP-12	2
7	Plug	ASP-13	2
8	Nipple	ASP-14	1
9	Nut	ASP-15	1
10	Valve	ASP-16	1 (*)
11	Shaft	ASP-17	1
12	Distributor	ASP-18	1 (*)
13	O-Ring	ASP-19	3
14	Washer	ASP-20	1
15	Washer	ASP-21	1
16	Nut	ASP-22	1
17	O-Ring	ASP-23	2
18	Cylinder	ASP-24	1
19	Nut	ASP-25	1
20	Joint	ASP-26	1
21	Base Cylinder	ASP-27	1
22	Joint	ASP-28	1
23	Body Cylinder	ASP-29	1
24	Pin	ASP-30	1
25	Spring	ASP-31	1
26	Nipple	ASP-32	2
27	Joint	ASP-33	2
28	Connector	ASP-34	1
29	Nut	ASP-35	1



GA-200
HYDRAULIC AIRLESS

**Parts Identification
& Manual Service**

Item	Description	Part Number	Qty.
30	Valve	ASP-36	1
31	Guide	ASP-37	1
32	Nipple	ASP-38	1
33	Pipe	ASP-39	1
34	Elbow	ASP-40	1
35	Motor Pump Rebuild Kit (*) Parts sold together	ASP-41	

GA-200
HYDRAULIC AIRLESS

**Parts Identification
& Manual Service**



DISPLACEMENT PUMP

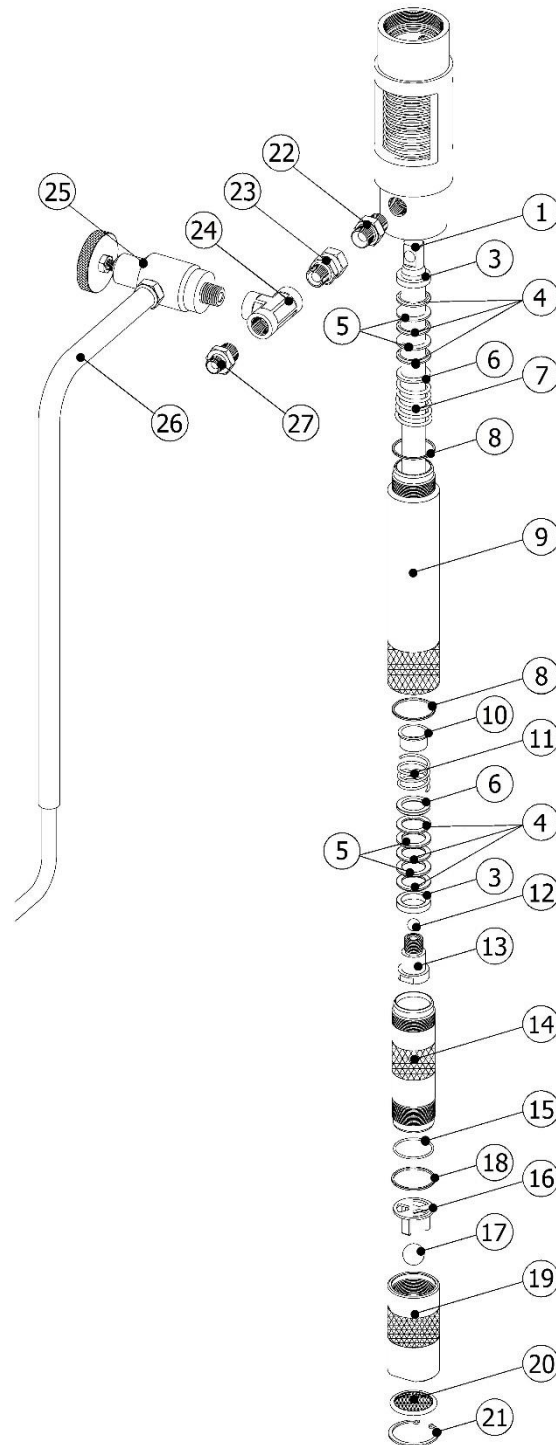

Figure 3. Displacement Pump, Parts List.



Table 4. Displacement Pump, Parts List

Item	Description	Part Number	Qty.
1	Rod	ASP-42	1
2	Displacement Pump Rebuilt kit (*) Parts included	ASP-5	
3	Female Gland	ASP-43	2 (*)
4	Packing	ASP-44	6 (*)
5	Packing	ASP-45	4 (*)
6	Male Gland	ASP-46	2 (*)
7	Spring	ASP-47	1
8	Joint	ASP-48	2
9	Cylinder	ASP-49	1
10	Spring Seat	ASP-50	1
11	Spring	ASP-51	1
12	Ball	ASP-52	1 (*)
13	Piston	ASP-53	1
14	Cylinder	ASP-54	1
15	O-Ring	ASP-55	1
16	Ball Guide	ASP-56	1
17	Ball	ASP-57	1 (*)
18	Joint	ASP-58	1
19	Valve	ASP-59	1
20	Filter	ASP-60	1
21	Washer	ASP-61	1
22	Nipple	ASP-62	1
23	Nut	ASP-63	1
24	"T"	ASP-64	1
25	Valve	ASP-65	1
26	Purge	ASP-66	1
27	Nipple	ASP-67	1

HYDRAULIC SYSTEM

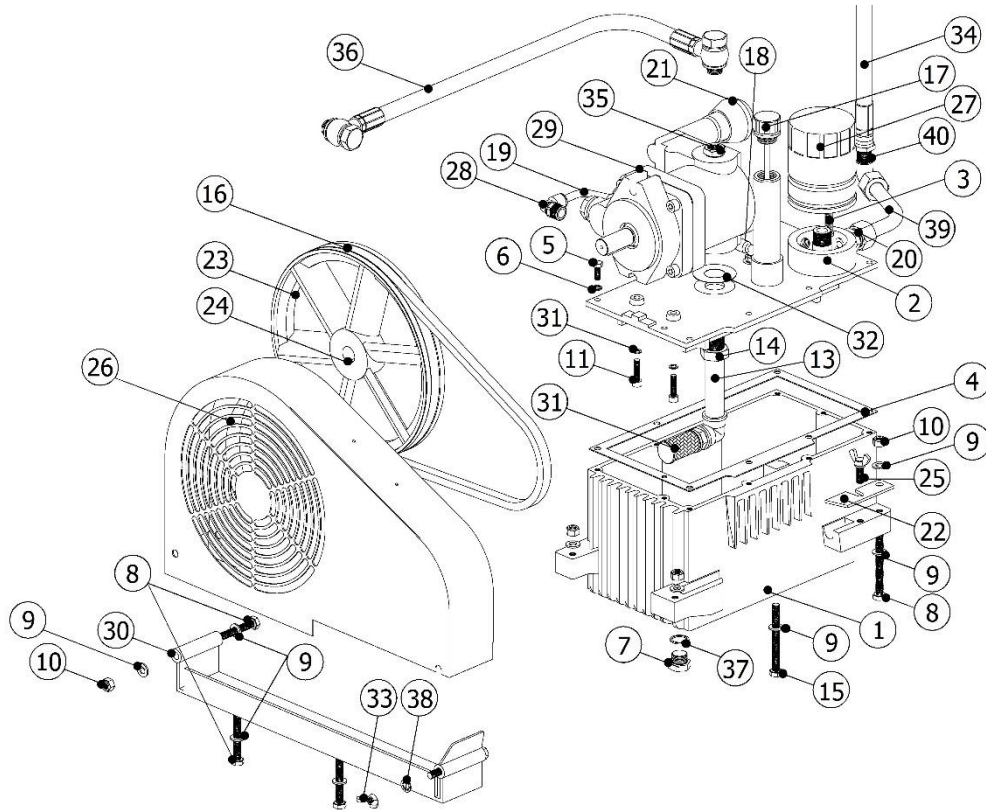

Figure 4. Hydraulic System, Parts List.

Table 5. Hydraulic System, Parts List

Item	Description	Part Number	Qty.
1	Tank	ASP-68	1
2	Cover	ASP-69	1
3	Valve	ASP-70	1
4	Joint	ASP-71	1
5	Screw	ASP-72	10
6	Washer	ASP-73	10
7	Plug	ASP-74	1
8	Screw	ASP-75	5



GA-200
HYDRAULIC AIRLESS

**Parts Identification
 & Manual Service**

Item	Description	Part Number	Qty.
9	Washer	ASP-76	8
10	Nut	ASP-77	4
11	Screw	ASP-78	2
12	Filter	ASP-79	1
13	Pipe	ASP-80	1
14	Nut	ASP-81	1
15	Screw	ASP-82	1
16	Belt	ASP-83	1
17	Dipstick	ASP-84	1
18	Elbow	ASP-85	1
19	Pipe	ASP-86	1
20	Nipple	ASP-87	1
21	Knop	ASP-88	1 (*)
22	Plate	ASP-89	1
23	Pulley	ASP-90	1
24	Pin	ASP-91	1
25	Screw	ASP-92	1
26	Cover	ASP-93	1
27	Filter	ASP-94	1
28	Elbow	ASP-95	1 (*)
29	Piston Pump	ASP-96	1 (*)
30	Support	ASP-97	1
31	Washer	ASP-98	2
32	Joint	ASP-99	1
33	Nut	ASP-100	1
34	Hose	ASP-101	1
35	Nipple	ASP-102	1 (*)
36	Hose	ASP-103	1
37	Washer	ASP-104	1
38	Washer	ASP-105	1
39	Pipe	ASP-106	1
40	Nipple	ASP-107	1
41	Hydraulic System Rebuilt Kit (*) Parts included	ASP-108	

GA-200
HYDRAULIC AIRLESS

Parts Identification
& Manual Service



MODEL WITH ELECTRIC MOTOR

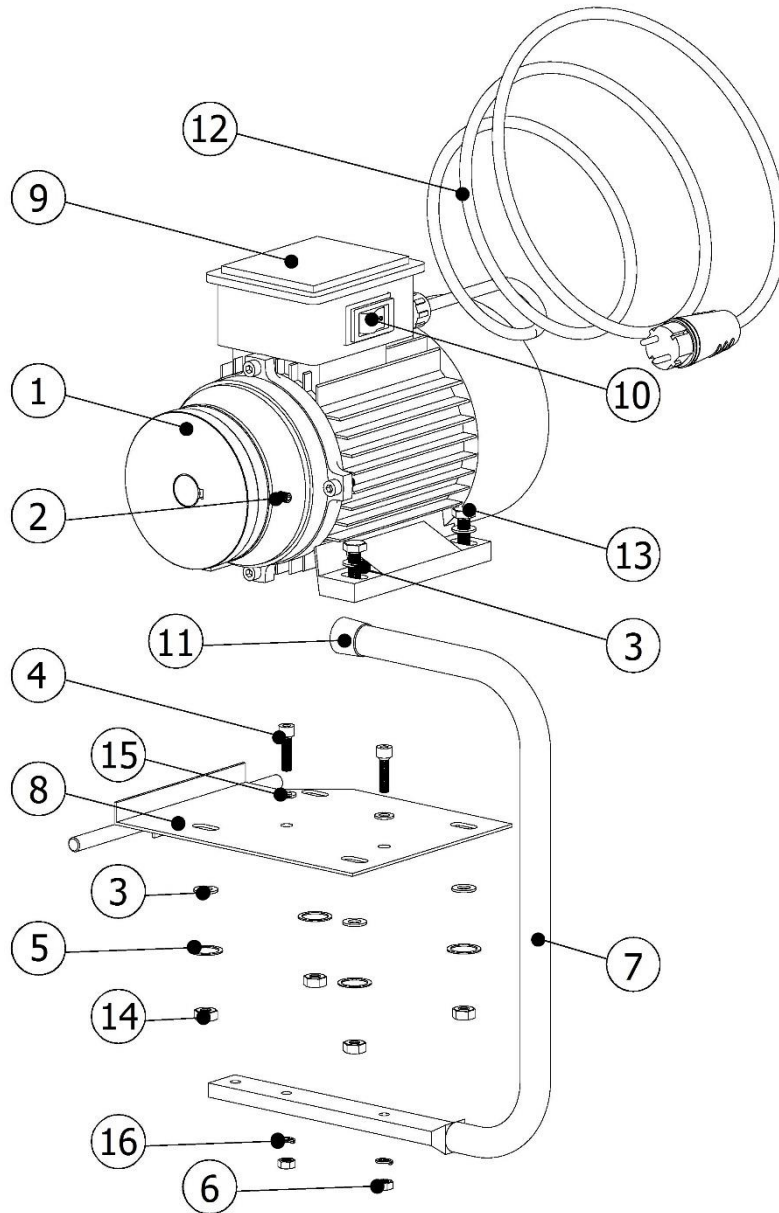

Figure 5. Model with Electric Motor, Parts List.



GA-200
HYDRAULIC AIRLESS

**Parts Identification
& Manual Service**

Table 6. Model with Electric Motor, Parts List

Item	Description	Part Number	Qty.
1	Pulley	ASP-109	1
2	Pin	ASP-110	1
3	Washer	ASP-111	8
4	Screw	ASP-112	2
5	Washer	ASP-113	4
6	Nut	ASP-114	2
7	Handle	ASP-115	1
8	Plate	ASP-116	1
9	Motor	ASP-117	1
10	Switch On/Off	ASP-118	1
11	Plug	ASP-119	1
12	Cable	ASP-120	1
13	Screw	ASP-121	4
14	Nut	ASP-122	4
15	Washer	ASP-123	2
16	Washer	ASP-124	2

If you need the Electric Motor kit separately, you should request the Part Number ASP-06.

GA-200
HYDRAULIC AIRLESS

**Parts Identification
& Manual Service**



MODEL WITH GASOLINE ENGINE

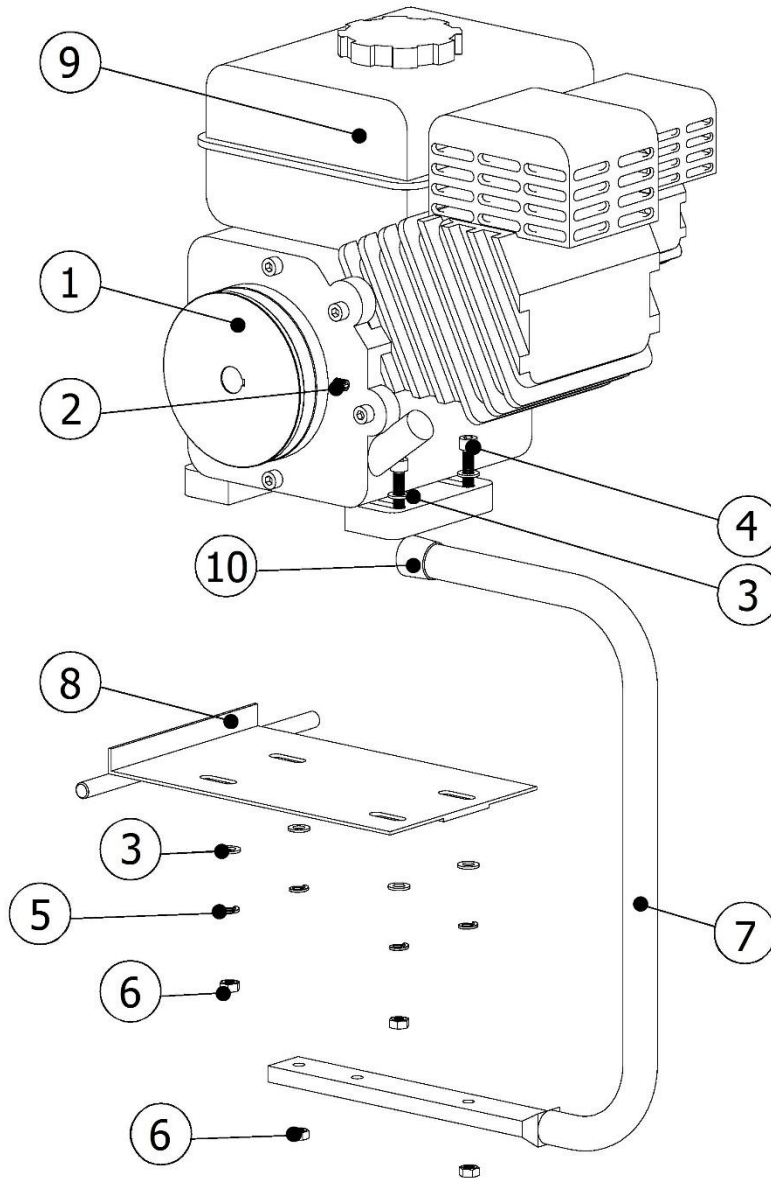

Figure 6. Model with Gasoline Engine, Parts List.



GA-200
HYDRAULIC AIRLESS

**Parts Identification
& Manual Service**

Table 7. Model with Gasoline Engine, Parts List

Item	Description	Part Number	Qty.
1	Pulley	ASP-125	1
2	Pin	ASP-110	1
3	Washer	ASP-123	8
4	Screw	ASP-112	4
5	Washer	ASP-124	4
6	Nut	ASP-114	4
7	Handle	ASP-115	1
8	Plate	ASP-126	1
9	Motor	ASP-127	1
10	Plug	ASP-119	1





If you need the Gasoline Motor kit separately, you should request the Part Number ASP-145.

GA-200
HYDRAULIC AIRLESS

**Parts Identification
 & Manual Service**



ACCESORIES

Description	Part Number	
KIT HP+FILTER+DRAIN VALVE, WHEN SPRAYING PAINTS	ASP-128	
(CARBON STEEL) 1,150 kg	ASP-129	
(ALUMINIUM) 0,900 kg	ASP-130	
		
(CARBON STEEL) 1,830 kg	ASP-131	
(ALUMINIUM) 1,430 kg	ASP-132	
		
SWIVEL CONNECTOR	ASP-133	
	ASP-134	
REVERSIBLE BASE (* <i>supplied with ASP-02 Part Number.</i>)	ASP-03	



GA-200
HYDRAULIC AIRLESS

**Parts Identification
& Manual Service**

Description	Part Number	
TIP EXTENSIONS	ASP-135	
		
AIRLESS GUN FILTER		
50 MESH (COLOR WHITE)	ASP-136	
100 MESH (COLOR YELLOW)	ASP-137	
200 MESH (COLOR RED)	ASP-138	
Airless GUN (see specific chapter in sheet 36)	ASP-02	
HOSES		
1/4" x 1 m (3.28 ft)	ASP-01	
1/4" x 15 m (49.2 ft)	ASP-139	
3/8" x 15 m (49.2 ft)	ASP-00	
1/2" x 15 m (49.2 ft)	ASP-140	
UNION		
3/8" M-M	ASP-141	
1/2" M-M	ASP-142	
1/4" M-M	ASP-143	
1/4" M- 3/8" M	ASP-144	

GA-200
HYDRAULIC AIRLESS

**Parts Identification
& Manual Service**



ORIFICE SIZE	Part Number	Fan Width at 300 mm	FLOW Litres/min
AUTO CLEAN TIP 	ASP-04.XX.XX		
0.89 mm / 0.035"	ASP-04.35.40*	200-250 (435)	4.96
0.68 mm / 0.027"	ASP-04.27.60	300-350 (627)	2.91
0.58 mm / 0.023"	ASP-04.23.20	100-150 (223)	2.08
0.46 mm / 0.018"	ASP-04.19.70	350-400 (719)	1.36

() TIP supplied with ASP-02 Part Number.*



GA-200 HYDRAULIC AIRLESS

Parts Identification & Manual Service

AIRLESS GUN

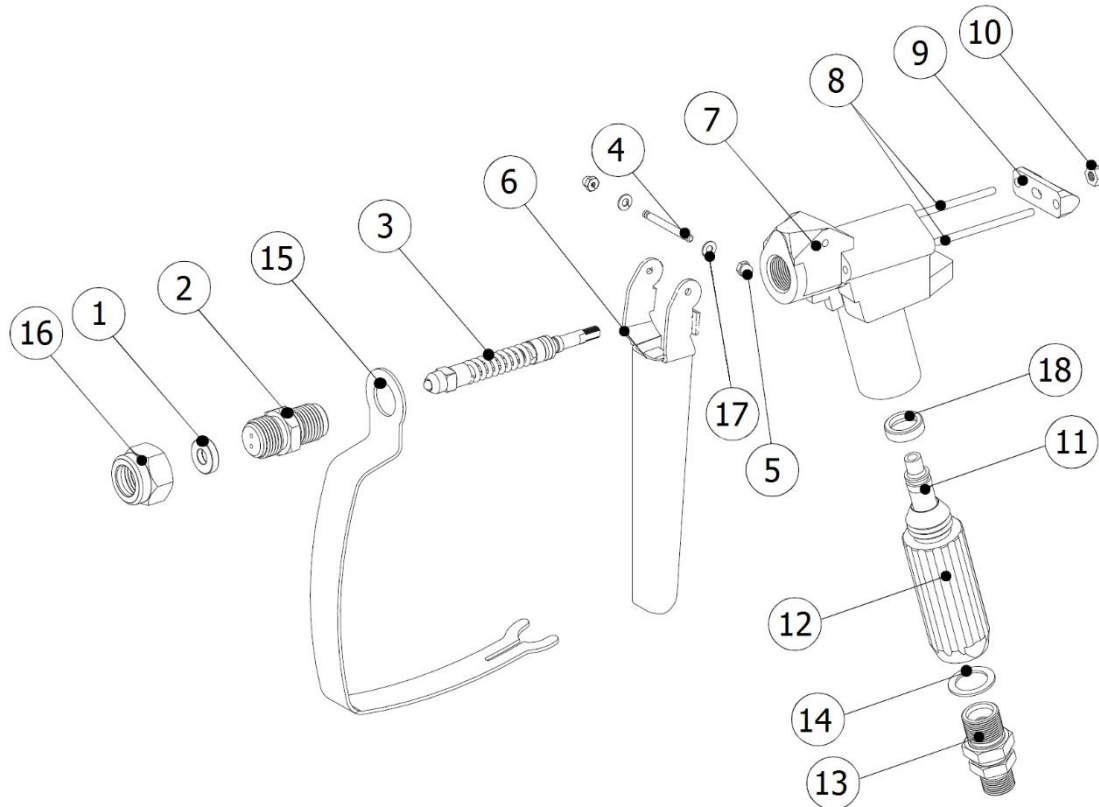

Figure 7. Airless Gun ASP-02 model, Parts List.

Weight with packaging:	0.620 kg (1.37 lb)
Weight without PCD:	0.530 kg (1.17 lb)
Dimensions of packaging:	235 x 175 x 47 (9.25 in x 6.89 in x 1.85 in)
Max. working pressure:	350 bar (5076 psi)
Inlet:	Male 1/4" BSP



Table 8. Airless Gun ASP-02 model, Parts List

Item	Description	Part Number	Qty.
1	Joint	ASP-146	1
2	Needle Seat	ASP-147	1
3	Needle	ASP-148	1
4	Trigger Shaft	ASP-149	1
5	Nut	ASP-150	2
6	Trigger	ASP-151	1
7	Body gun	ASP-152	1
8	Shaft	ASP-153	2
9	Needle Handle	ASP-154	1
10	Nut	ASP-155	1
11	Filter (50 Mesh)	ASP-136	2 (@)
12	Handle Gun	ASP-156	1
13	Swivel Union	ASP-157	1
14	Joint	ASP-158	1
15	Trigger Guard	ASP-159	1
16	Nut	ASP-160	1 (*)
17	Washer	ASP-161	2
18	Seat	ASP-162	1
19	Auto Clean TIP (not shown)	ASP-163	1
20	Reversible Base (not Shown)	ASP-03	1

(*) The item 1 & 16 (Joint & Nut) is only available for standard TIP, not supplied in ASP-02 Part Number.

(@) The gun assembly includes 1 Filter 50 Mesh (white) and another equal to replace.



GA-200

HYDRAULIC AIRLESS

Parts Identification & Manual Service

OBSERVATIONS

- The unit is delivered with full oil tank.
- The GA-200G unit with gasoline engine is delivered with the empty fuel tank.
- When ordering, you can choose the type of motor you want on the unit (E electrical or G gasoline).
- All orders will include a gun **ASP-02** with the standard configuration:
 - Gun Assembly
 - Auto Clean TIP **ASP-04.35.40**
 - Reversible Base **ASP-03**
 - Replacement Filter 50 Mesh (white) **ASP-136**

If you need another gun configuration, contact with Sales Department.

GA-200

HYDRAULIC AIRLESS

Parts Identification & Manual Service



CONTENT

Warranty	2
Safety and Handling	3
PRESSURE HAZARD	5
FIRE OR EXPLOSION HAZARD	5
GAS ENGINE (WHERE APPLICABLE)	5
PRESSURE RELIEVE PROCEDURE	5
GROUNDING INSTRUCTIONS	6
GASOLINE ENGINE SAFETY	6
Operation	8
PREPARING TO PAINT	9
PAINTING	10
PRESSURE RELIEVE PROCEDURE	12
Cleanup	13
CLEANING A CLOGGED TIP	14
Maintenance	15
DAILY MAINTENANCE	15
MAINTAINING THE HYDRAULIC SYSTEM	15
BASIC ENGINE MAINTENANCE (GAS ENGINE)	16
DAILY	16
FIRST 20 HOURS	16
EVERY 100 HOURS	16
WEEKLY	16
ENGINE OPERATION SERVICE	16
Troubleshooting	17
Technical Specifications	19
Mechanical (with Electrical Motor)	19
Mechanical (with Gasoline Engine)	19
General Description	20
Motor Pump	22
Displacement Pump	25
hydraulic System	27
Model with Electric Motor	29
Model with Gasoline Engine	31
Accesories	33
Airless Gun	36
Observations	38
Content	39
List of tables	40
List Of Illustrations	40



GA-200

HYDRAULIC AIRLESS

Parts Identification & Manual Service

LIST OF TABLES

Table 1. GA-200 model, General Description	21
Table 2. GA-200, Available models	21
Table 3. Motor Pump, Parts List	23
Table 4. Displacement Pump, Parts List	26
Table 5. Hydraulic System, Parts List	27
Table 6. Model with Electric Motor, Parts List	30
Table 7. Model with Gasoline Engine, Parts List	32
Table 8. Airless Gun ASP-02 model, Parts List	37

LIST OF ILLUSTRATIONS

Figure 1. GA-200 model, General Description.	20
Figure 2. Motor Pump, Parts List.	22
Figure 3. Displacement Pump, Parts List.	25
Figure 4. Hydraulic System, Parts List.	27
Figure 5. Model with Electric Motor, Parts List.	29
Figure 6. Model with Gasoline Engine, Parts List.	31
Figure 7. Airless Gun ASP-02 model, Parts List.	36